

INSTALLATION MANUAL

PRODUCT: **RECOVERY POINTS**
MODEL: **VW Amarok (2016-)**
PART NUMBER: **2D.5810.1**



WARNING!

In order to reduce the risk of severe injury or property damage: Before installation and use of this product read the whole procedure, paying special attention to the safety notice and installation notice! Upon installation or maintenance of this product it is necessary to use protective glasses. Check integrity of the design and torque settings of fasteners in each 1000km of the vehicle usage. Do not use this product if there is any damage to the design or fasteners

In order to reduce the risk of severe injury or property damage: Before installation and use of this product read the whole

RECOVERY POINTS

Part Number:	2D.5810.1
Suited to vehicle:	Volkswagen Amarok 2016-
Material:	Steel
Dimensions:	440x240x300 mm 17,3x9,4x11,8 inch
Weight:	15 kg / 33 pound
Compatibility:	Skid Plates: 2333.5836.1.6 2111.5836.1.3 Winch Plate: 2L.5801.1



SAFETY NOTICE

- * The RIVAL recovery points are designed to compliment the use and design of the specified vehicle under conditions specified by the car manufacturer.
- * The operation of a vehicle where the recovery points are not properly attached and fastened to the vehicle, or where it has been damaged, must be avoided at all cost.
- * It is recommended that you carry out regular inspections of all fittings
- * It is not allowed to load recovery point with force of more than that specified herein.

INSTALLATION NOTICE

- * The recovery points should be mounted in strict compliance with this procedure in specialized service centers
- * During installation it is required to use personal protective equipment.
- * Do not install this recovery points onto the vehicle models other than those specified herein.

REQUIRED TOOLS

- * Basic tool kit
- * Torque wrench
- * Angle grinder
- * Marker
- * Scotch tape
- * Masking tape

TORQUE SETTINGS

- * M8 - 25 N·m,
- * M10 - 50 N·m,
- * M12 - 80 N·m.
- * M16 - 220 N·m.

PARTS LISTING

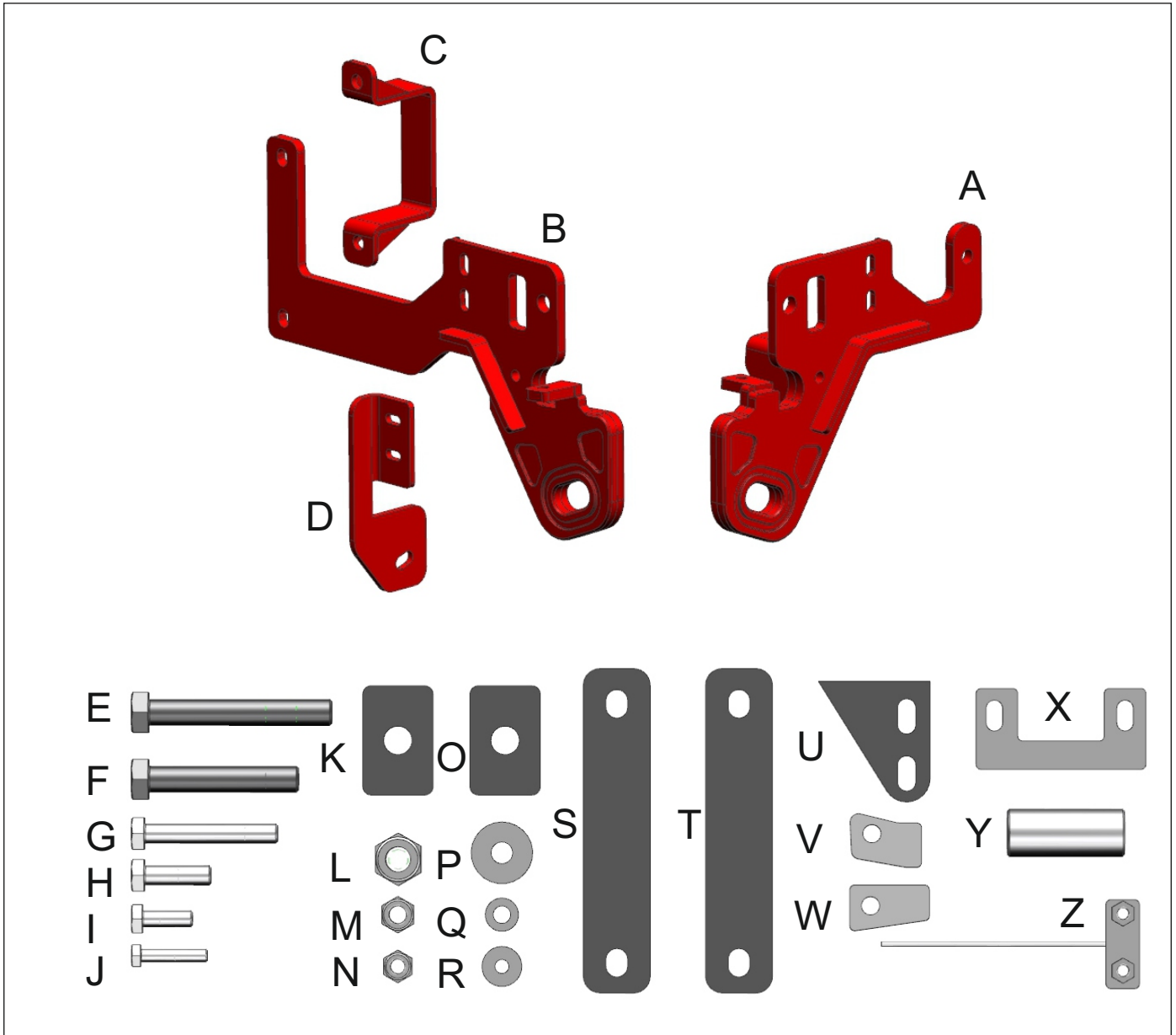

A. Left recovery point.....	Qty 1
B. Right recovery point.....	Qty 1
C. Clamp.....	Qty 1
D. Skid plate bracket.....	Qty 1
E. Bolt M16x120.....	Qty 2
F. Bolt M16x100.....	Qty 1
G. Bolt M12x80.....	Qty 1
H. Bolt M12x40.....	Qty 2
I. Bolt M10x35.....	Qty 2
J. Bolt M8x40.....	Qty 6
K. Washer 1,8 мм.....	Qty 9
L. Nylock nut M16	Qty 2
M. Nylock nut Гайка M12	Qty 1
N. Nylock nut M10.....	Qty 2

O. Washer 4 мм.....	Qty 3
P. Washe 12 увеличенная.....	Qty 4
Q. Washe 10.....	Qty 4
R. Washe 8 увеличенная.....	Qty 6
S. Rear right insert plate 1.8 mm ...	Qty 1
T. Rear right insert plate 4 mm	Qty 1
U. Insert plate 1.....	Qty 2
V. Front left insert plate.....	Qty 4
W. Front right insert plate	Qty 2
X. Bottom left insert plate.....	Qty 2
Y. Bushing	Qty 1
Z. Insert nut M8.....	Qty 1

INSTALLATION MANUAL



1. Open the bonnet.
2. Disconnect the negative battery terminal cable.



3. Unscrew 4 screws securing the radiator grille.
* **Set aside for re-use later.**



4. In the wheel arches of the vehicle unscrew 2 screws securing underwing flap to the bumper on each side.
* **Set aside for re-use later.**



5. Unbend the bumper mounts slightly on each side.

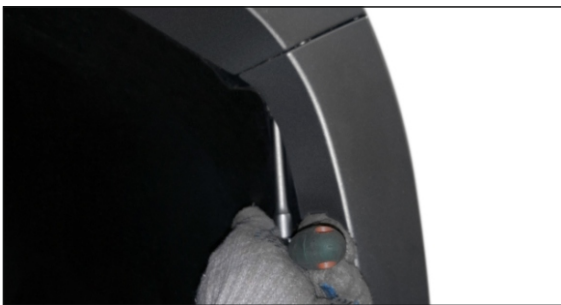

6. In the wheel arches of the vehicle unscrew the screw mounting bumper to the body on each side.
* **Set aside for re-use later.**



7. Unscrew 2 screws on each side in the bottom part of bumper.
* **Set aside for re-use later.**

INSTALLATION MANUAL

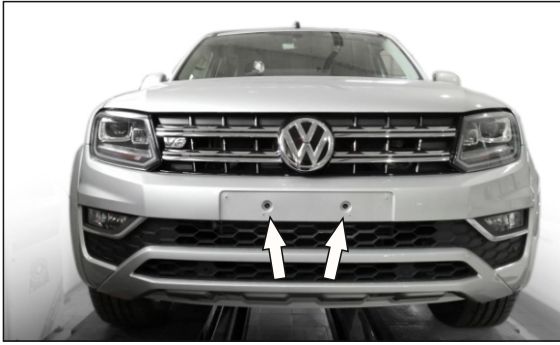

8. Remove the license plate bracket and unscrew 2 bumper mount screws.
* **Set aside for re-use later.**



9. Dismantle the bumper. To do this, gently pull the edge of the bumper and unfasten the bumper from the latches on each side.

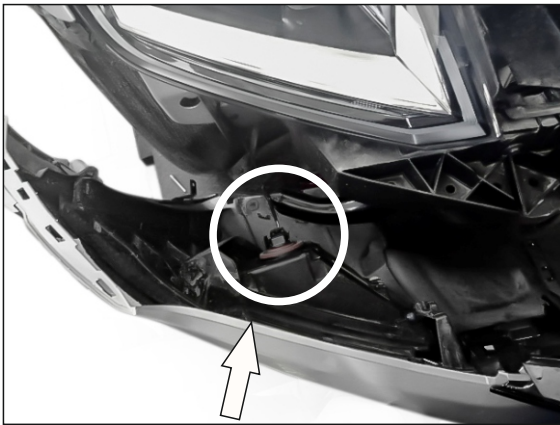

10. Disconnect all the electrical connectors from the bumper.



11. Remove the bumper.

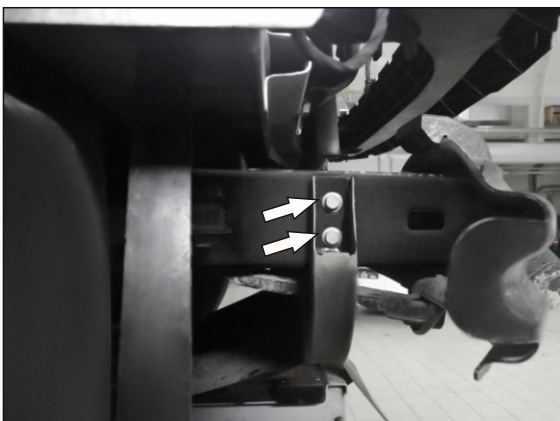

12. Unscrew 2 bolts securing skid plate on the right side.

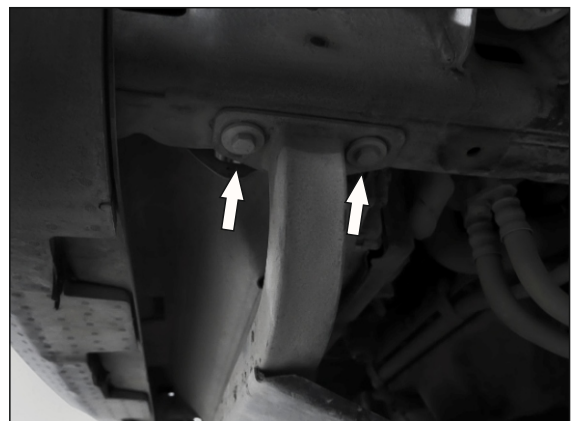

13. Unscrew 2 bolts securing skid plate on the left side.

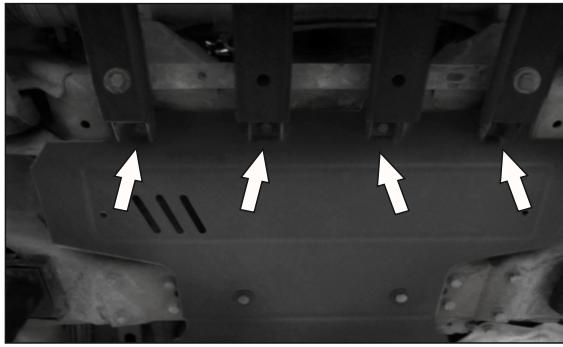

14. Unscrew 4 bolts securing skid plate at the bottom of the car.

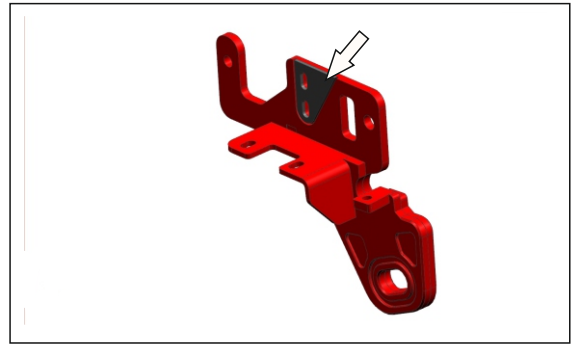

15. When installing recovery points use insert plates pos. U, in all the cases, except for installation together with a winch plate L.5801.1. In this case, the flanges of the winch bracket are inserted in place of spacers.

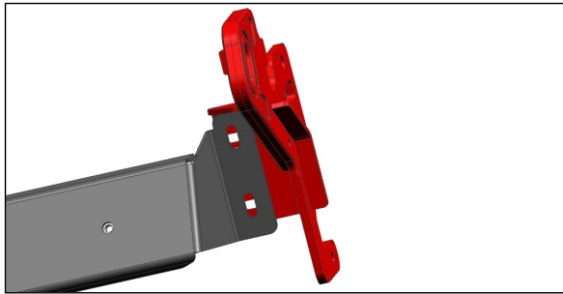

16. When installing the left recovery point with RIVAL skid plate, the beam is mounted on top of recovery point as shown in the figure.

*** Parts are installed at the same time.**

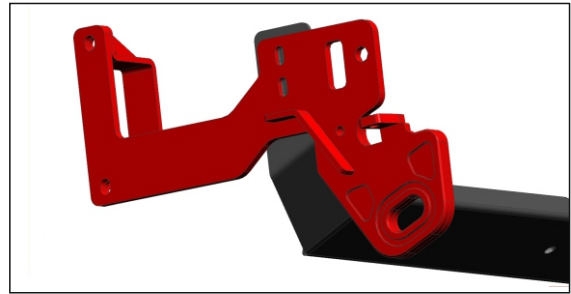

17. When installing the right recovery point with RIVAL skid plate, the beam is mounted under the hinge as shown in the figure.

*** Parts are installed at the same time.**

Carry out steps 18-23 only when installing recovery points together with OE skid plate

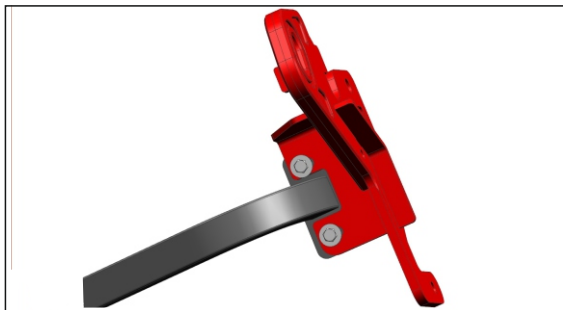

18. When installing the left recovery point with the OE skid plate, recovery point is installed on top of the skid plate bracket as shown.

*** Parts are installed at the same time.**

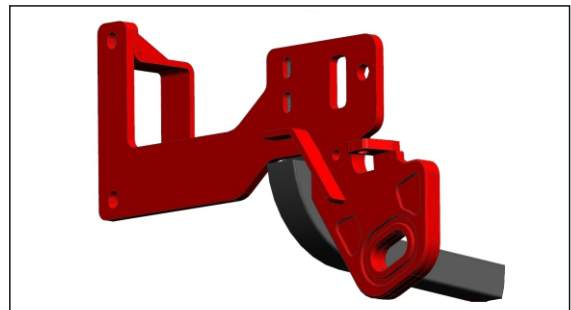

19. When installing the right recovery point with OE skid plate, recovery point is installed on top of the skid plate bracket (see step 20) as shown.

*** Parts are installed at the same time.**

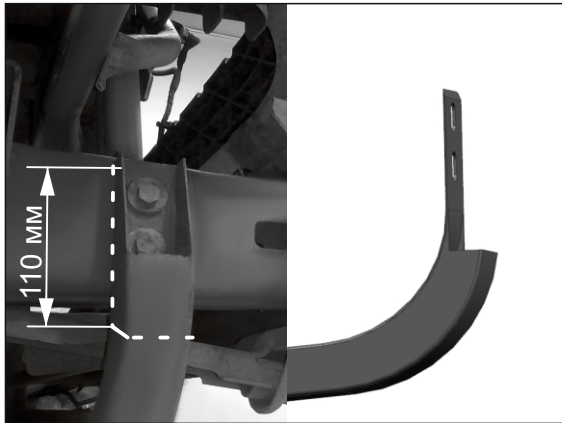

20. To perform step 19, cut the skid plate bracket on the right side, so that it turned out as shown above. To do this, pre-mark the bracket.

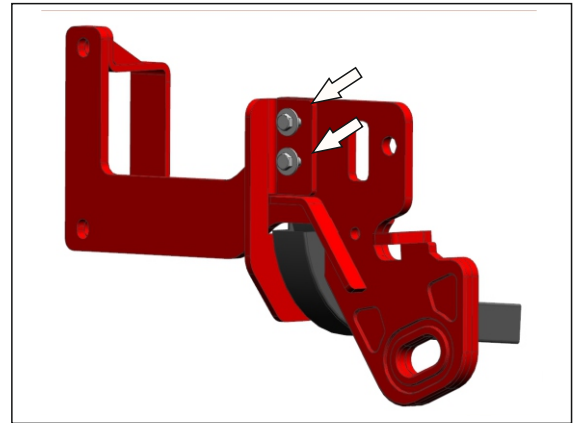

21. Connect together the skid plate, right recovery point and bracket pos. D, using bolts M8.

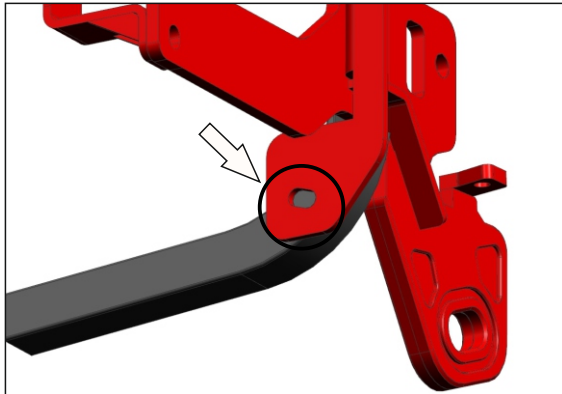

22. Mark the place for drilling and drill a hole with diameter of 12.5-13 mm.

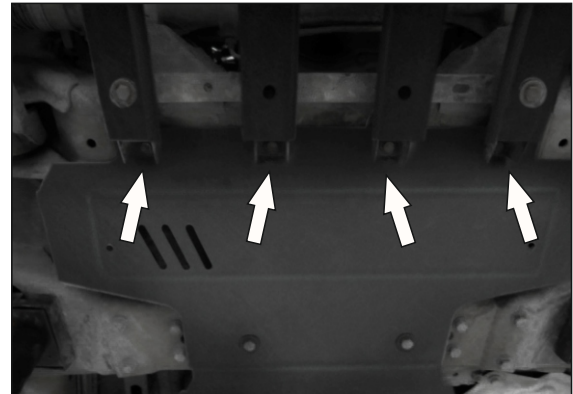

23. If towing hinges are installed the OE skid plate, first install the skid plate, using the rear mounting points (see step 14).



24. Place the left recovery point to the vehicle frame from outside; match the holes number 1 and number 2.



25. Mark the place for cutout on the damper. If recovery points are installed with RIVAL winch plate, perform cutout with 3 mm displacement to lateral sides of the car.



26. Remove the recovery point and cut a portion of the damper along the intended line.



27. Place the left recovery point (see step 21) to the vehicle frame, tighten the bolts M8x40 in the holes number 1 at the bottom of the recovery point.
Do not tighten yet.



28. Put the insert plate pos. Z, inside the frame through the hole on the inside and pre-bend the wire on the insert plate in place.



29. Match the holes in the insert plate with the holes in the frame and the recovery point, as shown and tighten bolts M8x40 in them.
Do not tighten yet.

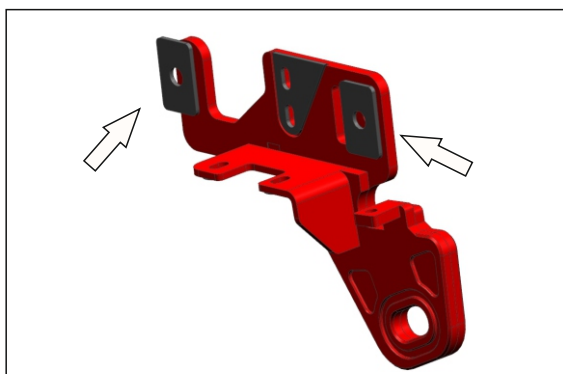

30. When installing the recovery points with RIVAL winch plate, use washers pos. K, in places of fastening with the bolts M16 as shown.



31. Install bushing into the frame at the rear part of the recovery point, on the inside, then screw the bolt M16x100 with washer pos. K, into the body of the recovery point, on the inside of the frame through the bushing.

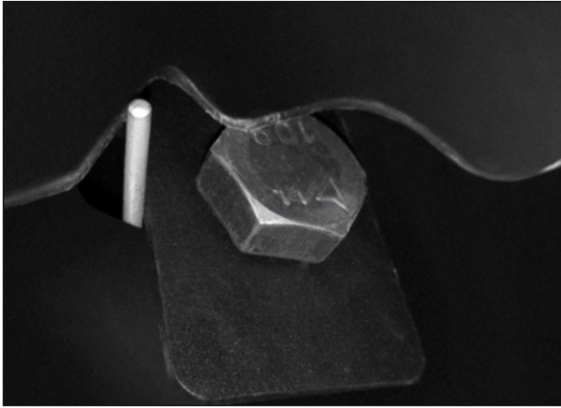

32. Install the bolt M16x120 with washer pos. K, in the hole on the inside of the frame at the front part.



33. Install the washer pos. K, and nut M16 on the bolt M16, on the side of the recovery point.

Do not tighten yet.



34. Press the hinge to the frame and upward as much as possible, tighten all the hardware.



35. Mark the place for drilling across the hole and drill the hole using a drill with diameter of 10.5-11 mm



36. Install the bolt M10x35 with washers 10 and the nut M10 into the hole. Place inserts pos. W, if necessary, between the recovery point and the body to eliminate gap.

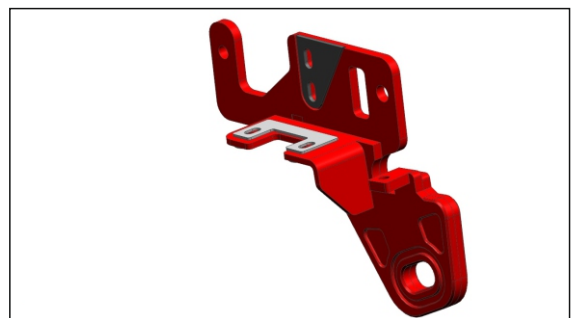

37. If any gap occurs at the bottom of the recovery mounting point (see step 24), unscrew the bolts M8, place inserts pos. X, as shown and screw the bolts back in.



38. Place the recovery point to the car frame by matching the holes, you may screw the bolts M8, mark the place for cutout in the damper (see items 21 and 22).



39. Remove the recovery point, cut the damper along the intended line (see step 23).



40. Place the recovery point and screw 2 bolts M8x40.
Do not tighten yet.

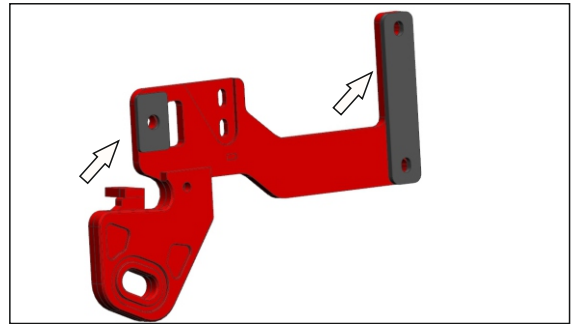

41. When installing the hinge with RIVAL winch plate or OE skid plate, place inserts pos. K and pos. S between the frame and the recovery point. When installing with RIVAL skid plate, use inserts pos. O and pos. T.



42. Install the bolt M16x120 with washers pos. K, and the nut M16 on the inside of the frame as shown.
Do not tighten yet.



43. Install clamp, item C on the car frame.

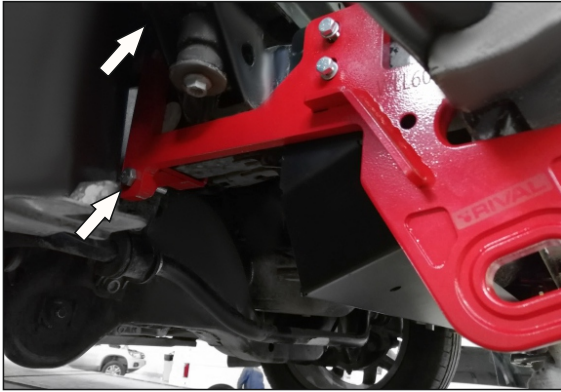

44. Attach the clamp to the recovery point with 2 bolts M12x40.
Do not tighten yet.



45. Slightly tighten all the hardware, mark and drill the hole with 10.5-11mm drill bit to secure the front bracket (similarly to step 32).

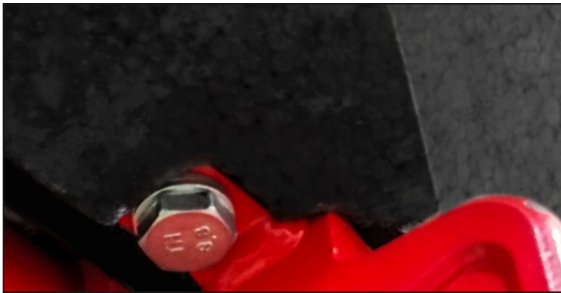

46. Install the bolt M10x35 with washers 10 and the nut M10 into the hole. Place inserts.



47. Press the recovery point to the frame and high up as possible, tighten all the hardware.

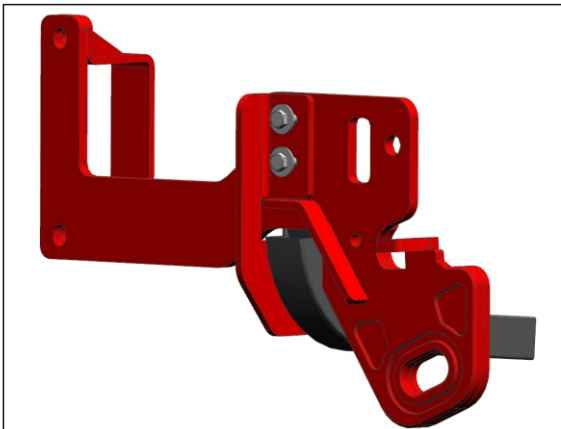

48. When installing recovery point together with the OE skid plate, unscrew bolts M8, install the bracket pos. D.

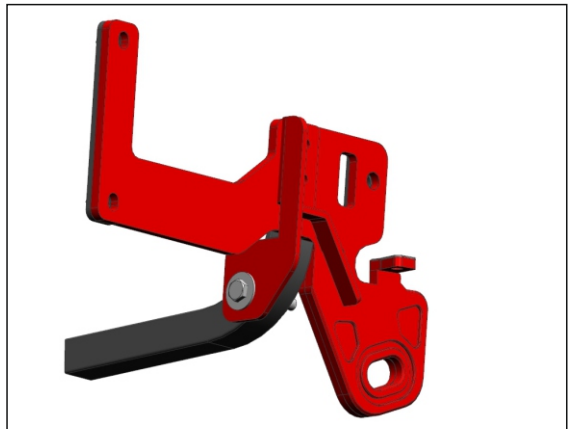

49. Connect the bracket of the OE skid plate with the bracket pos. D using bolt M12x80 , washers 12 and nut 12.



50. Check tightening of all the hardware.

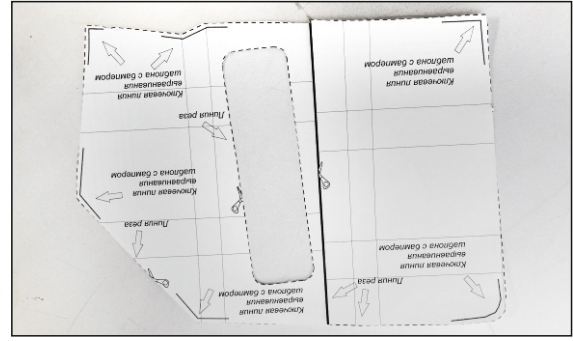

51. Cut the template (see Attachment 1) according to the instructions, connect both parts and fix them with scotch tape.



52. Place the template to the bumper. Align the faces marked on the template with the bumper faces and fix them with scotch tape. Pre-paste over part of the bumper at place of cutout with painter's tape for easier marking.



53. Mark the place for cutout in the bumper. Remove the template. Cut a hole in the bumper along the marked path.

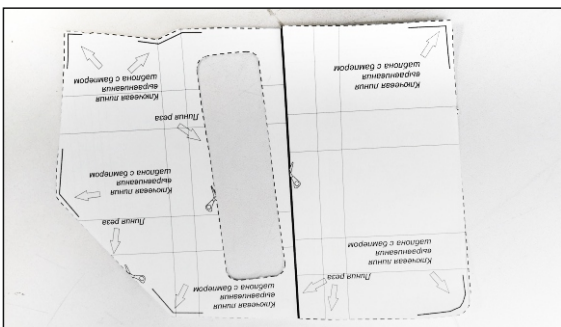

54. Repeat steps 52-53 on the opposite side of the bumper. To use the same template, turn over it, as shown.



55. Try on the bumper. If necessary, extend the holes for the recovery points, for unobstructed bumper installation.

56. Install the bumper in the reversed order to removal, check operation capacity of all the electrical systems, installed in the bumper. Make sure there is at least 3 mm clearance on each side between the bumper and the recovery points. In the absence of the necessary clearance, return to step 55.

INSTALLATION MANUAL

Before operating a vehicle fitted with a RIVAL recovery points:

- make sure that all screw joints are tightened;
- check integrity of all recovery points components.



Attachment 1
TEMPLATE
Cutout in bumper
(SECOND PART)

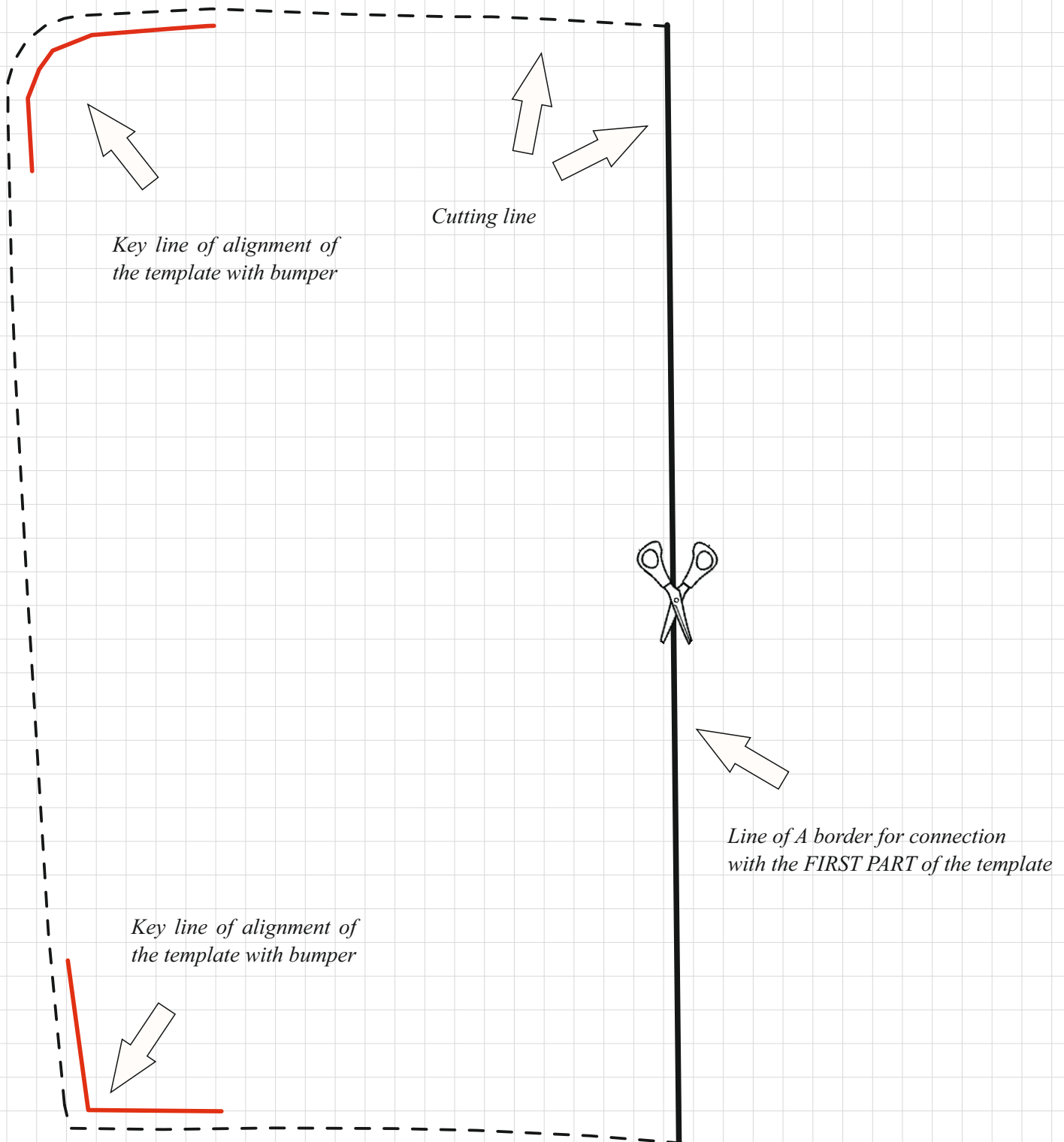

Apply the resulting template to the bumper surface according to the installation instructions. For more accurate marking fix the template on the bumper with scotch tape in places, not marked with the line of alignment of the faces. This template is used for the LEFT and RIGHT sides of the bumper in the direction of the car travel. For the opposite side, turn over the template.

Attachment 1
TEMPLATE
Cutout in bumper
(FIRST PART)

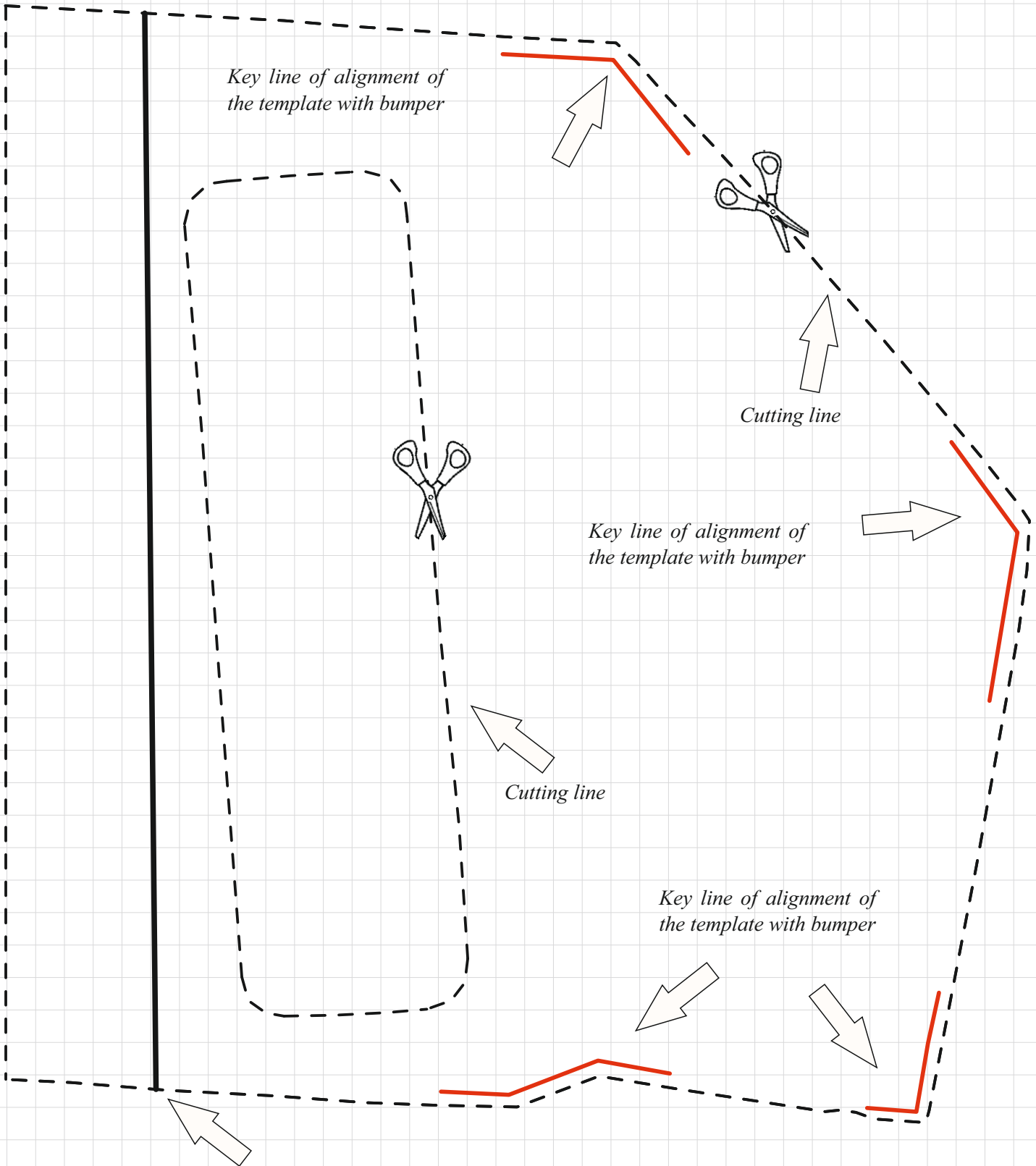

Put the SECOND PART of the template on the FIRST ONE to the left of this line. Align the line of A border with the specified line. Glue 2 halves with scotch tape